

## P-Channel Trench Power MOSFET

### General Description

The G18P03S uses advanced trench technology to provide excellent  $R_{DS(ON)}$ , low gate charge and operation with gate voltages as low as -5V. This device is suitable for use as a wide variety of applications.

### Features

●

$V_{DS}$	$R_{DS(ON)}$ @-4.5V(TYP)	$R_{DS(ON)}$ @-10V(TYP)	$I_D$
-30V	10.5m $\Omega$	8.1m $\Omega$	-15A

- High Power and current handling capability
- RoHS Compliant
- Surface Mount Package

### Application

- DC-DC converter
- Load switch
- Power management

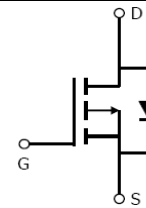

Schematic Diagram

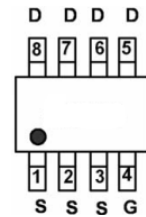

Marking and pin assignment

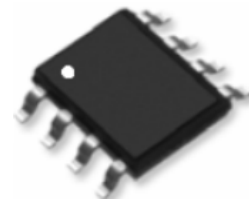

SOP-8

## Ordering Information

Part Number	Marking	Case	Packaging
G18P03S	G18P03	SOP-8	4000pcs/Reel

Table 1. Absolute Maximum Ratings ( $T_A=25^\circ\text{C}$ )

Symbol	Parameter	Value	Unit
$V_{DS}$	Drain-Source Voltage ( $V_{GS}=0V$ )	-30	V
$V_{GS}$	Gate-Source Voltage ( $V_{DS}=0V$ )	$\pm 20$	V
$I_D$	Drain Current-Continuous( $T_C=25^\circ\text{C}$ )	-15	A
$I_{DM (pluse)}$	Drain Current-Continuous@ Current-Pulsed (Note 1)	-60	A
$P_D$	Maximum Power Dissipation( $T_C=25^\circ\text{C}$ )	3.1	W
$T_J, T_{STG}$	Operating Junction and Storage Temperature Range	-55 To 150	$^\circ\text{C}$

Table 2. Thermal Characteristic

Symbol	Parameter	Typ	Max	Unit
$R_{\theta JC}$	Thermal Resistance, Junction-to-Case	--	40	$^\circ\text{C/W}$

**Table 3. Electrical Characteristics (TA=25°C unless otherwise noted)**

Symbol	Parameter	Conditions	Min	Typ	Max	Unit
<b>On/Off States</b>						
BV <sub>DSS</sub>	Drain-Source Breakdown Voltage	V <sub>GS</sub> =0V I <sub>D</sub> =-250μA	-30			V
I <sub>DSS</sub>	Zero Gate Voltage Drain Current	V <sub>DS</sub> =-30V, V <sub>GS</sub> =0V			-1	μA
I <sub>GSS</sub>	Gate-Body Leakage Current	V <sub>GS</sub> =±20V, V <sub>DS</sub> =0V			±100	nA
V <sub>GS(th)</sub>	Gate Threshold Voltage	V <sub>DS</sub> =V <sub>GS</sub> , I <sub>D</sub> =-250μA	-1.1	-1.6	-2.5	V
g <sub>FS</sub>	Forward Transconductance	V <sub>DS</sub> =-5V, I <sub>D</sub> =-10A		28		S
R <sub>DS(ON)</sub>	Drain-Source On-State Resistance	V <sub>GS</sub> =-10V, I <sub>D</sub> =-10A		8.1	10	mΩ
		V <sub>GS</sub> =-4.5V, I <sub>D</sub> =-6 A		10.5	15	mΩ
<b>Dynamic Characteristics</b>						
C <sub>iss</sub>	Input Capacitance	V <sub>DS</sub> =-15V, V <sub>GS</sub> =0V, f=1.0MHz		3570		pF
C <sub>oss</sub>	Output Capacitance			435		pF
C <sub>rss</sub>	Reverse Transfer Capacitance			175		pF
<b>Switching Times</b>						
t <sub>d(on)</sub>	Turn-on Delay Time	V <sub>DD</sub> =-15V, I <sub>D</sub> =-1A, R <sub>L</sub> =15Ω V <sub>GS</sub> =-10V, R <sub>G</sub> =2.5Ω		16		nS
t <sub>r</sub>	Turn-on Rise Time			14		nS
t <sub>d(off)</sub>	Turn-Off Delay Time			50		nS
t <sub>f</sub>	Turn-Off Fall Time			22		nS
Q <sub>g</sub>	Total Gate Charge	V <sub>GS</sub> =-10V, V <sub>DS</sub> =-15V, I <sub>D</sub> =-10A		58		nC
Q <sub>gs</sub>	Gate-Source Charge			9		nC
Q <sub>gd</sub>	Gate-Drain Charge			14		nC
<b>Source-Drain Diode Characteristics</b>						
I <sub>S</sub>	Source-Drain Current(Body Diode)				-15	A
V <sub>SD</sub>	Forward on Voltage	V <sub>GS</sub> =0V, I <sub>S</sub> =-10A			-1.2	V

Notes 1.Repetitive Rating: Pulse width limited by maximum junction temperature

## Switch Time Test Circuit and Switching Waveforms:

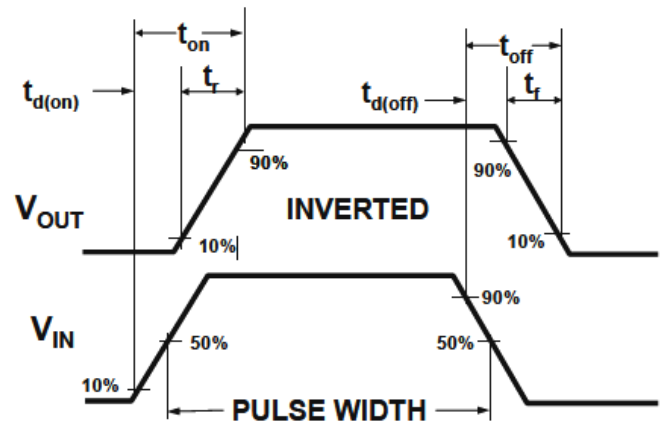
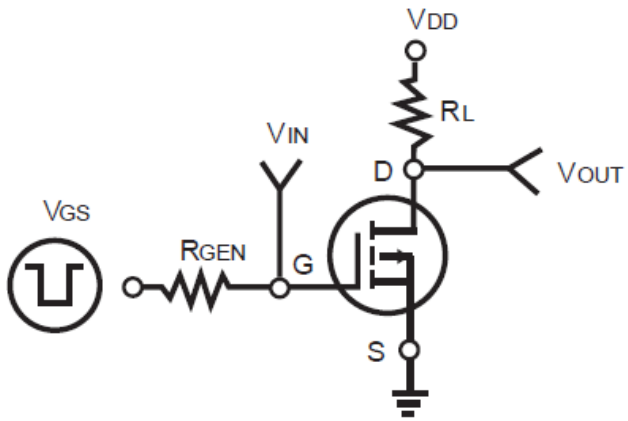

## TYPICAL ELECTRICAL AND THERMAL CHARACTERISTICS (Curves)

Figure1. Power Dissipation

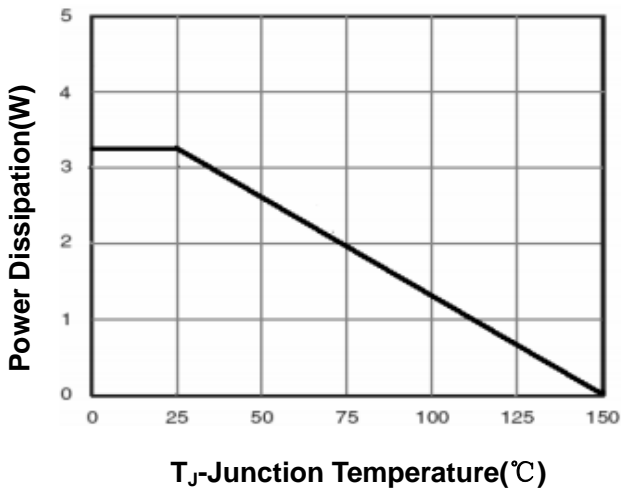

Figure2. Transfer Characteristics

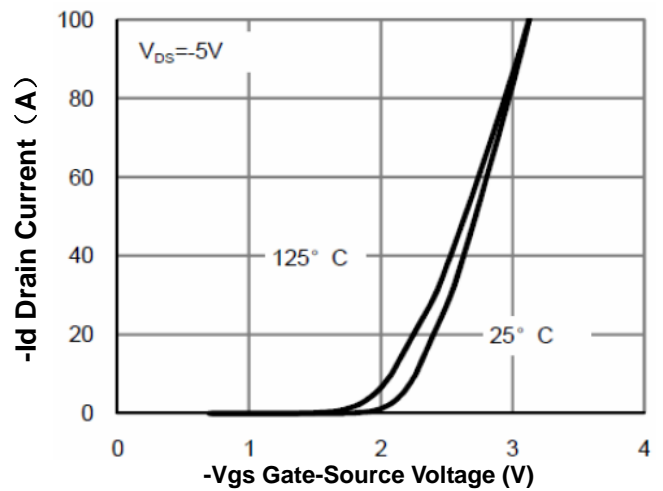

Figure3. Output Characteristics

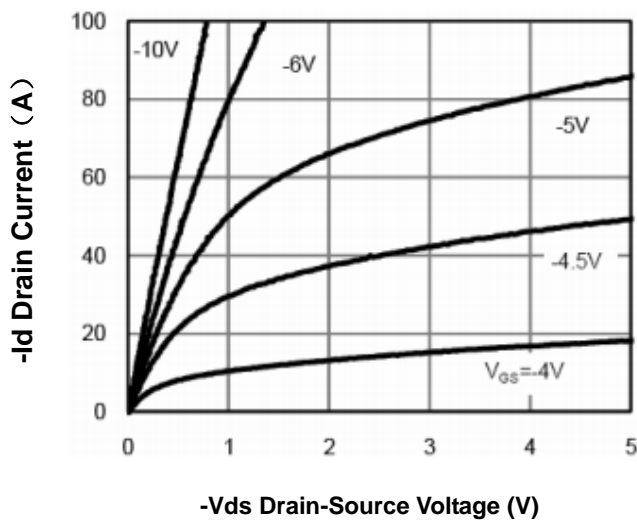

Figure 4.  $R_{DS(on)}$  Drain Current

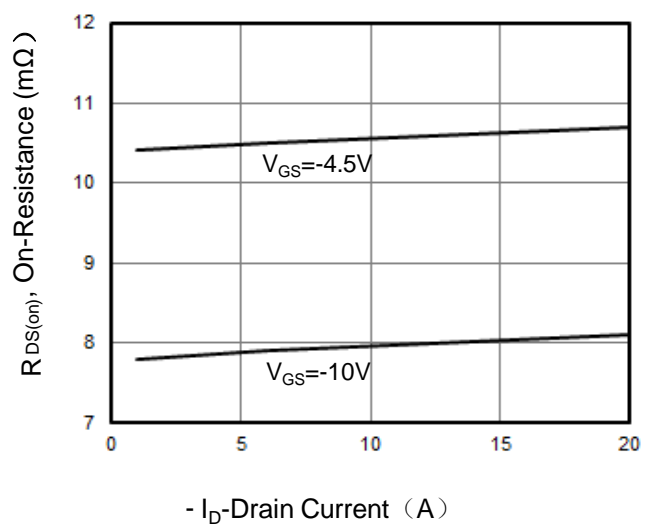

Figure5. Capacitance

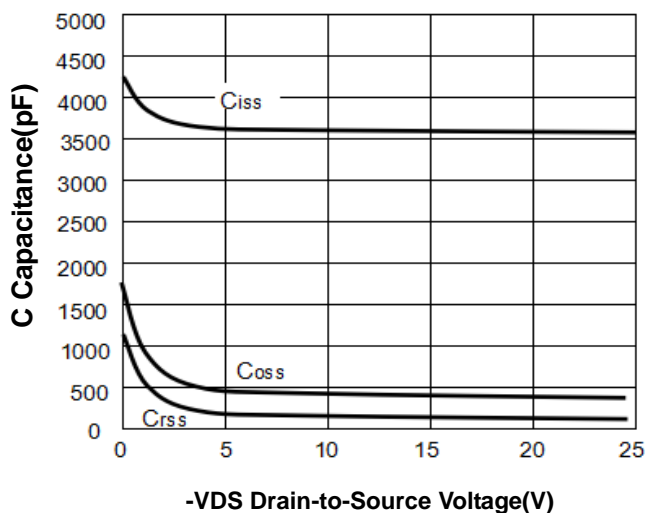

Figure6.  $R_{DS(ON)}$  vs Junction Temperature

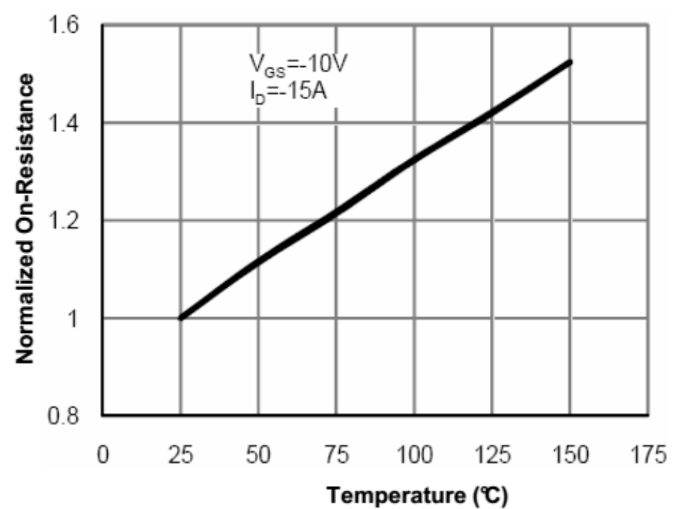

Figure7. Gate Charge Waveforms

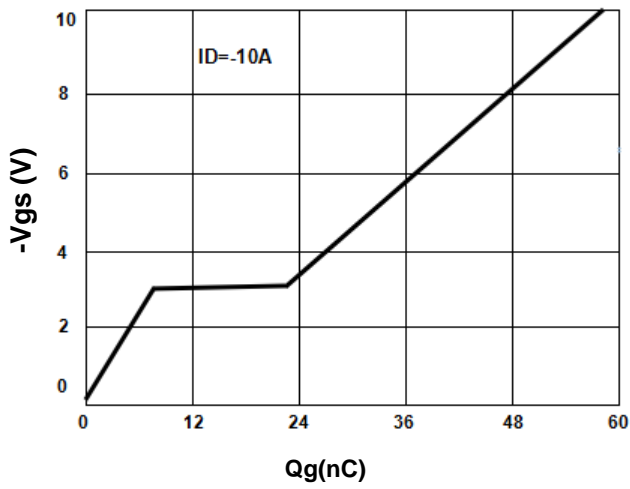

Figure8. Maximum Safe Operating Area

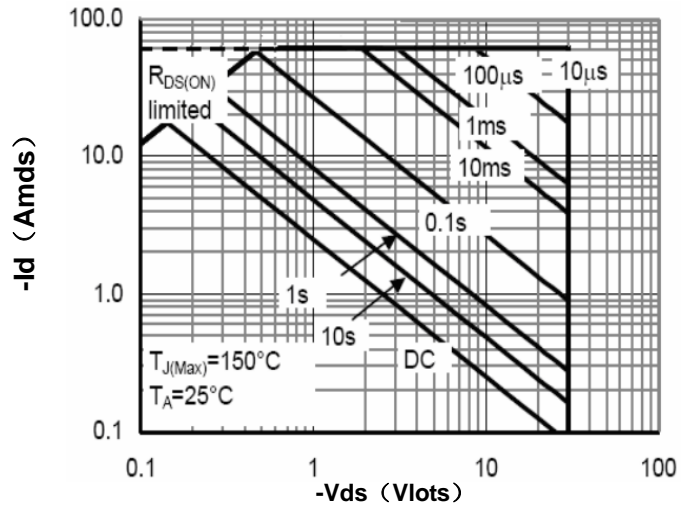
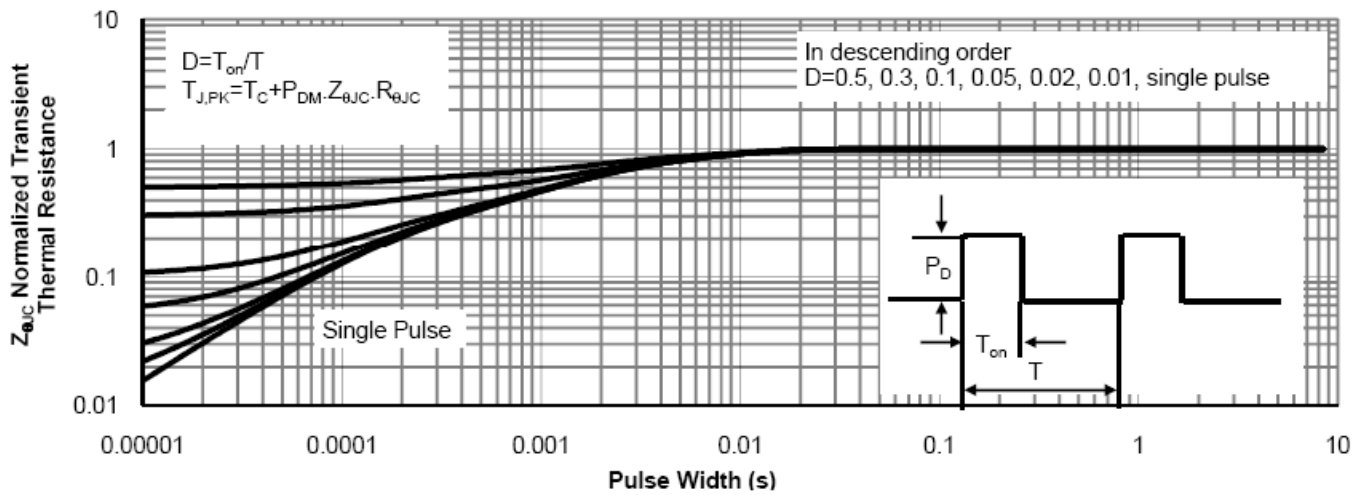
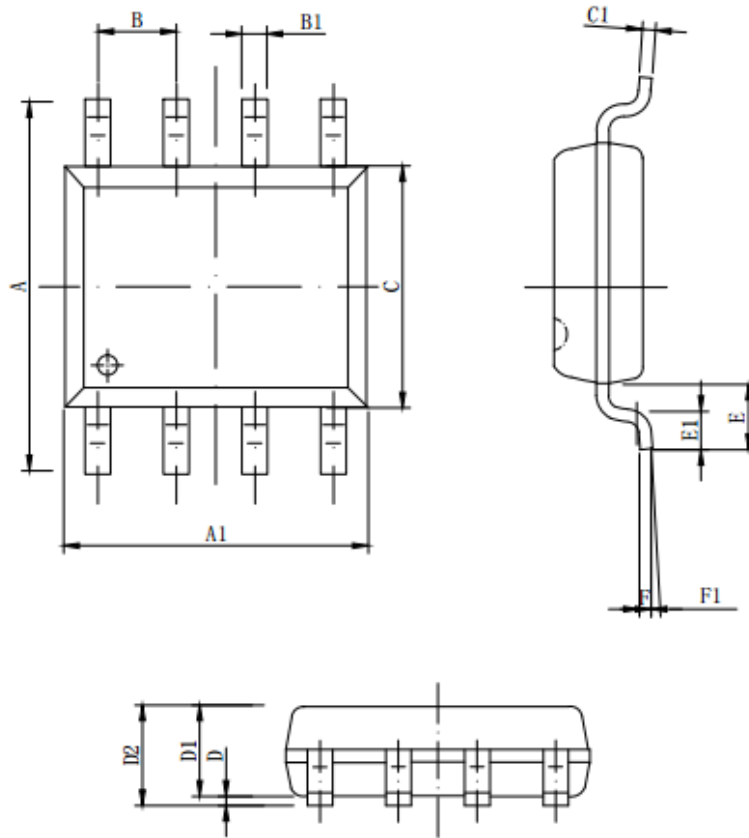

Figure9. Normalized Maximum Transient Thermal Impedance



**SOP-8 Package Information**



Symbol	Dimensions in Millimeters		
	MIN.	NOM.	MAX.
A	5.800	6.000	6.200
A1	4.800	4.900	5.000
B	1.270BSC		
B1	0.35 <sup>±</sup> 0.05	0.40 <sup>±</sup> 0.05	0.45 <sup>±</sup> 0.05
C	3.780	3.880	3.980
C1	--	0.203	0.253
D	0.050	0.150	0.250
D1	1.350	1.450	1.550
D2	1.500	1.600	1.700
D2	1.500	1.600	1.700
E	1.060REF		
E1	0.400	0.700	0.100
F	0.250BSC		
F1	2°	4°	6°